



SOT-23 ESD 静电保护二极管

■ Features 特点

Two Bidirectional Lines 两个双向
ESD Protection 静电保护

■ Applications 应用

Portable electronics 便携式电子产品
Control & monitoring systems 控制与监视系统
Cellular handsets and accessories 蜂窝手机及配件
Servers, notebooks, and desktop PCs bus protection
服务器、笔记本及台式机总线保护

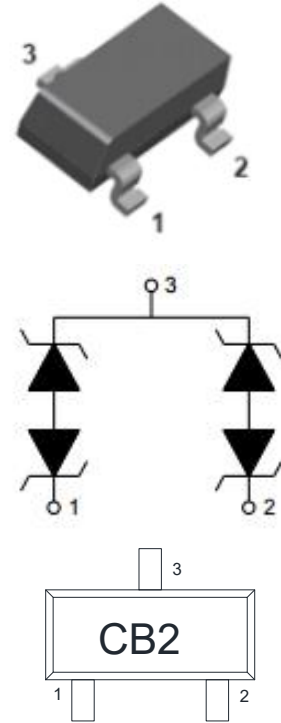

■ Internal Schematic Diagram 内部结构

■ Device Marking 产品打标

■ Absolute Maximum Ratings 最大额定值

Characteristic 特性参数	Symbol 符号	Rat 额定值	Unit 单位
ESD (IEC61000-4-2 contact discharge) @25°C接触放电	V_{ESD}	± 30	KV
ESD (IEC61000-4-2 air discharge) @25°C空气放电	V_{ESD}	± 30	KV
Peak Pulse Power @25°C峰值脉冲功率	P_{PK}	450	W
Peak Pulse Current @25°C峰值脉冲电流	I_{PP}	8	A
Lead Temperature 管脚温度	T_L	260	°C
Lead Solder Time 管脚焊接时间	T_L	10	S
Operating Temperature 工作温度	T_{op}	-40~125	°C
Junction Temperature 结温	T_J	-55~150	°C
Storage Temperature 储存温度	T_{stg}	-55~150	°C

■ Electrical Characteristics 电特性

($T_A=25^{\circ}\text{C}$ unless otherwise noted 如无特殊说明, 温度为 25°C)

Characteristic Parameters 特性参数	Symbol 符号	Min 最小值	Typ 典型值	Max 最大值	Unit 单位	Condition 条件
Reverse Stand-off Voltage 反向工作电压	V_{RWM}			24	V	
Reverse Breakdown Voltage 反向击穿电压	V_{BR}	26.5	28		V	$I_T=1\text{mA}$
Reverse Leakage Current 反向漏电流	I_R			1	μA	$V_{RWM}=24\text{V}$
Clamping Voltage 钳位电压	V_C		36		V	$I_{PP}=1\text{A}, t_p=8/20\mu\text{s}$
Clamping Voltage 钳位电压	V_C		48		V	$I_{PP}=8\text{A}, t_p=8/20\mu\text{s}$
Diode Capacitance 二极管电容	C_D		30		pF	$V_R=0\text{V}, f=1\text{MHz}$

V_{RWM}	Reverse Working Voltage 反向工作电压
$V_{R(BR)}$	Reverse Breakdown Voltage 反向击穿电压@ $I_T=1\text{mA}$
I_T	Test Current 测试电流
I_R	Reverse Leakage Current 反向漏电流@ V_{RWM}
V_C	Clamping Voltage 钳位电压
I_{PP}	Reverse Peak Pulse Current 浪涌电流
C_D	Diode Capacitance 二极管电容 $V_{I0}=0\text{V}, V_{P-P}=30\text{mV}, f=1\text{MHz}$

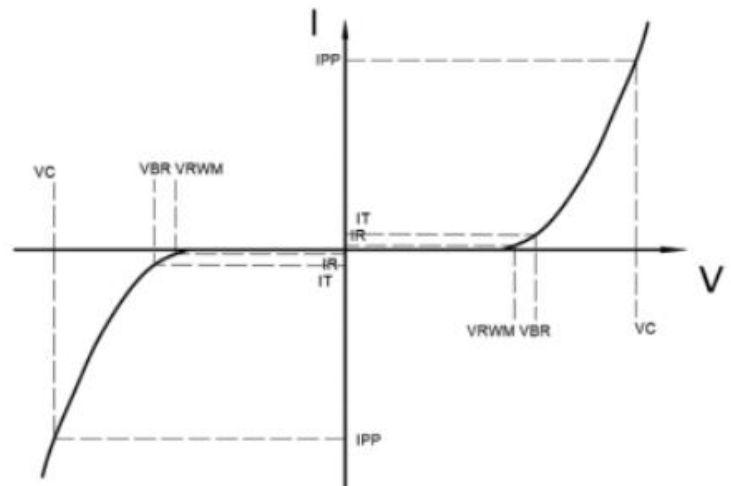

■ Typical Characteristic Curve 典型特性曲线

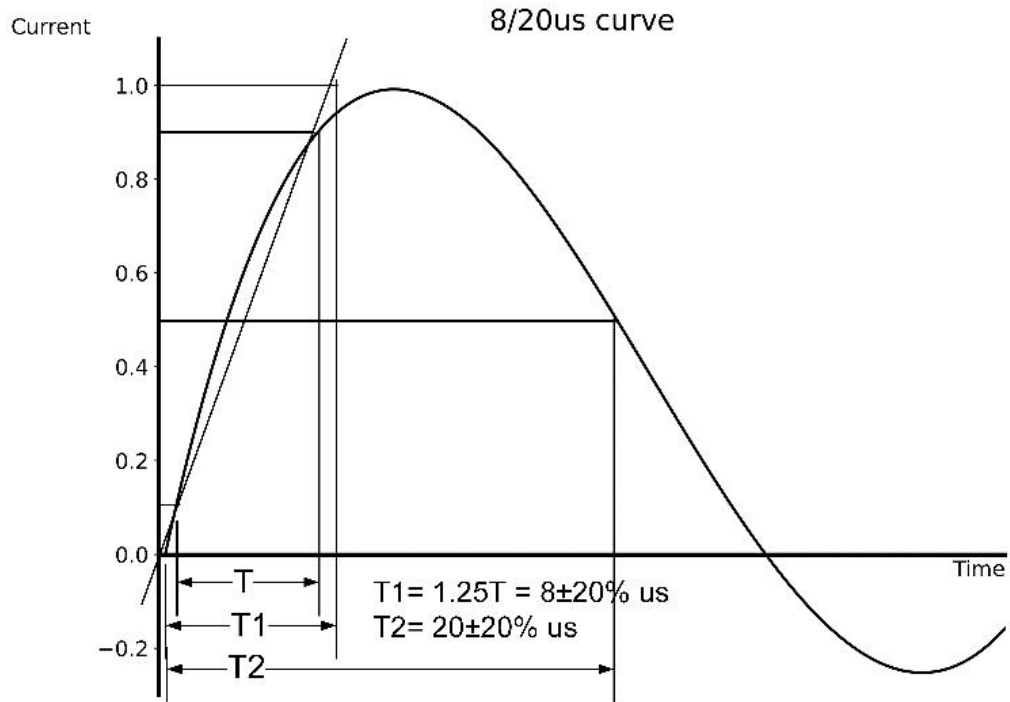

■ Typical Application 典型应用

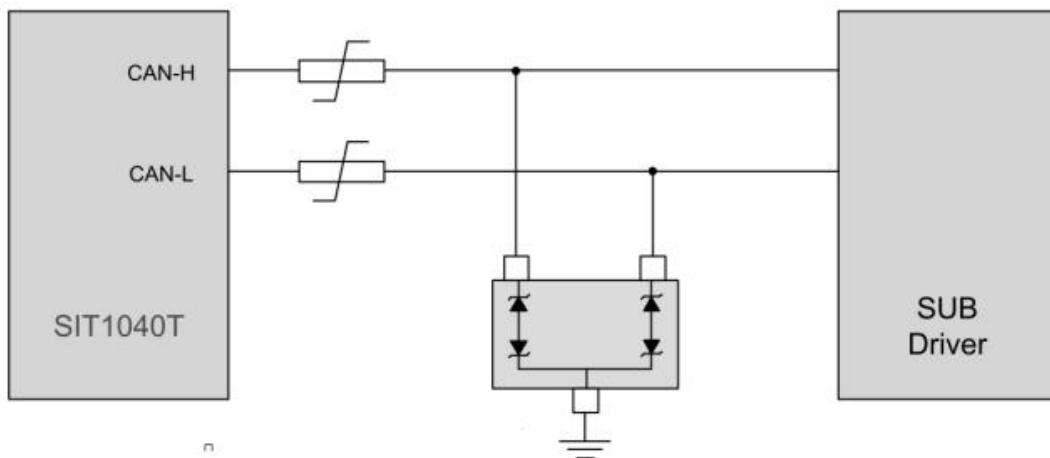

Dimension 外形封装尺寸

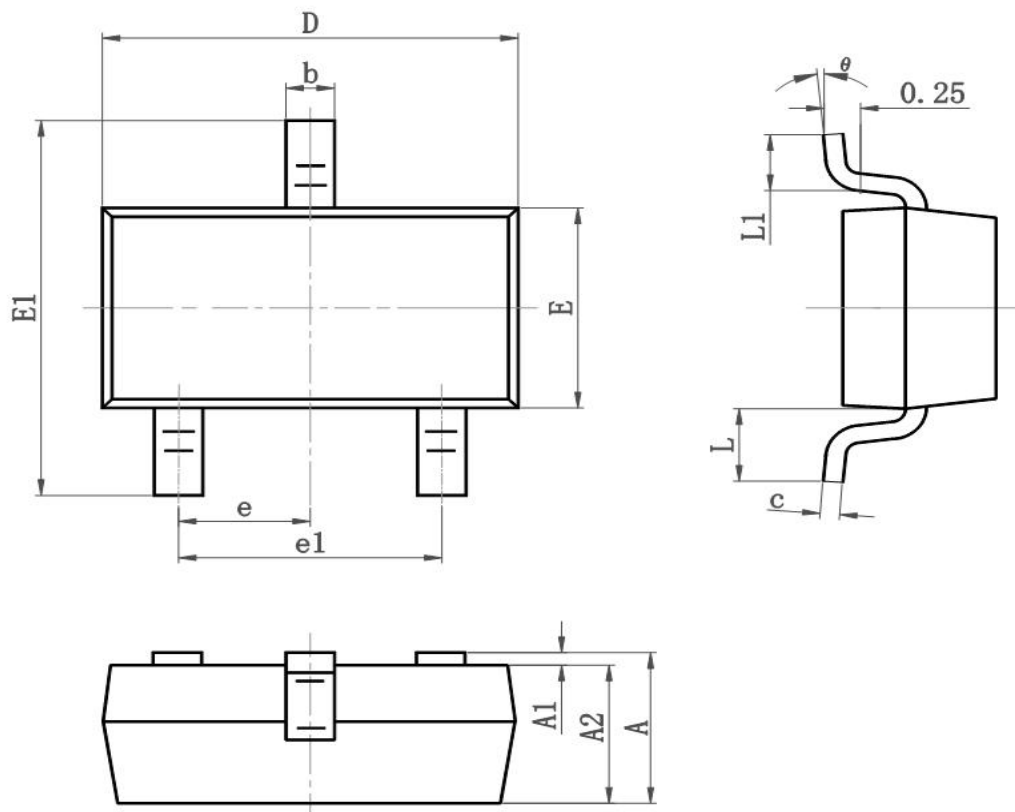

Symbol	Dimensions In Millimeters		Dimensions In Inches	
	Min	Max	Min	Max
A	0.900	1.150	0.035	0.045
A1	0.000	0.100	0.000	0.004
A2	0.900	1.050	0.035	0.041
b	0.300	0.500	0.012	0.020
c	0.080	0.150	0.003	0.006
D	2.800	3.000	0.110	0.118
E	1.200	1.400	0.050	0.055
E1	2.250	2.550	0.089	0.100
e	0.950TYP		0.037TYP	
e1	1.800	2.000	0.071	0.079
L	0.550REF		0.022REF	
L1	0.300	0.500	0.012	0.020
θ	0°	8°	0°	8°