



安徽富信半导体科技有限公司

ANHUI FOSAN SEMICONDUCTOR TECHNOLOGY CO., LTD.

SS32-SS310

SMC Schottky Barrier Rectifier Diode 肖特基势垒整流二极管

■ Features 特点

Low forward voltage drop 低正向压降

High current capability 高电流能力

Surface mount device 表面贴装器件

Case 封装:SMC(DO-214AB)

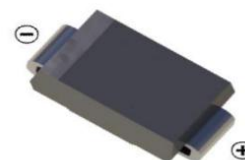

■ Maximum Rating 最大额定值

($T_A=25^{\circ}\text{C}$ unless otherwise noted 如无特殊说明, 温度为 25°C)

Characteristic 特性参数	Symbol 符号	SS32	SS33	SS34	SS35	SS36	SS38	SS39	SS310	Unit 单位
Peak Reverse Voltage 反向峰值电压	V_{RRM}	20	30	40	50	60	80	90	100	V
DC Reverse Voltage 直流反向电压	V_R	20	30	40	50	60	80	90	100	V
RMS Reverse Voltage 反向电压均方根值	$V_{R(RMS)}$	14	21	28	35	42	56	63	70	V
Forward Rectified Current 正向整流电流	I_F	3								A
Peak Surge Current 峰值浪涌电流	I_{FSM}	80								A
Thermal Resistance J-A 结到环境热阻	$R_{\theta JA}$	10								$^{\circ}\text{C}/\text{W}$
Junction Temperature 结温	T_J	150								$^{\circ}\text{C}$
Storage Temperature 储藏温度	T_{stg}	-65to+150 $^{\circ}\text{C}$								$^{\circ}\text{C}$

■ Electrical Characteristics 电特性

($T_A=25^{\circ}\text{C}$ unless otherwise noted 如无特殊说明, 温度为 25°C)

Characteristic 特性参数	Symbol 符号	SS32-SS34	SS35-SS36	SS38-SS310	Unit 单位	Condition 条件
Forward Voltage 正向电压	V_F	0.55	0.70	0.85	V	$I_F=3\text{A}$
Reverse Current 反向电流	$I_R(25^{\circ}\text{C})$ (100°C)	0.1 5		0.02 2	mA	$V_R=V_{RRM}$
Diode Capacitance 二极管电容	C_D	300			pF	$V_R=4\text{V}, f=1\text{MHz}$

■ Typical Characteristic Curve 典型特性曲线

FIG.1-TYPICAL FORWARD CURRENT DERATING CURVE

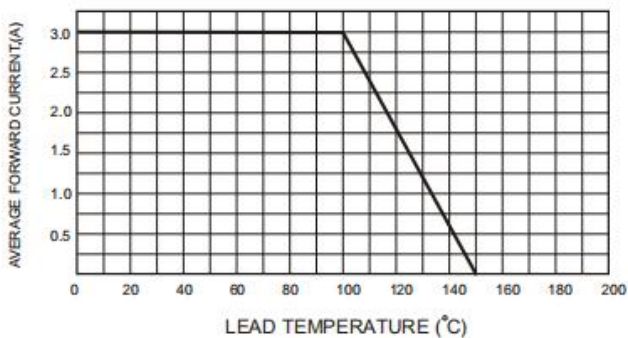

FIG.2-TYPICAL FORWARD CHARACTERISTICS

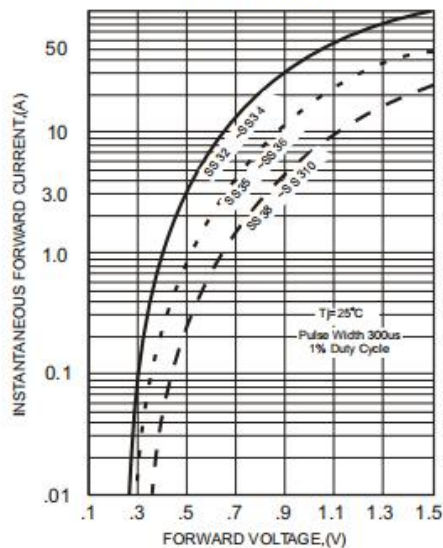

FIG.3-MAXIMUM NON-REPETITIVE FORWARD SURGE CURRENT

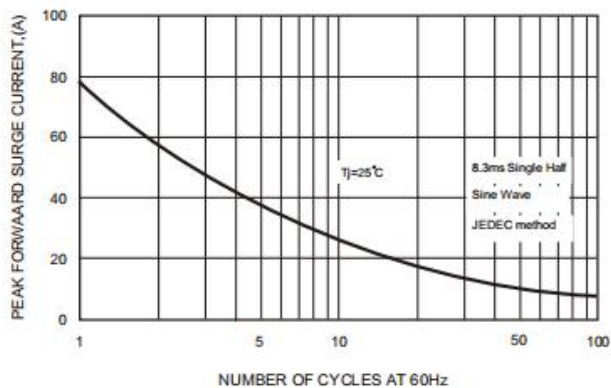

FIG.5 - TYPICAL REVERSE CHARACTERISTICS

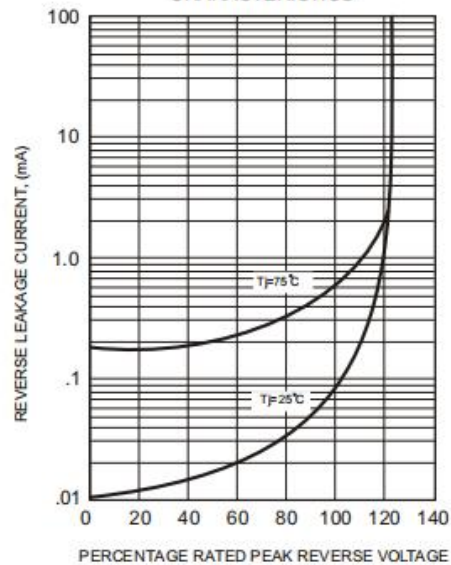
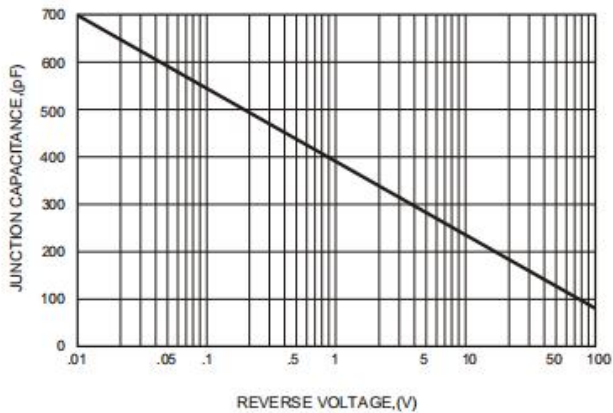

FIG.4-TYPICAL JUNCTION CAPACITANCE





■Dimension 外形封装尺寸

DO-214AB(SMC)

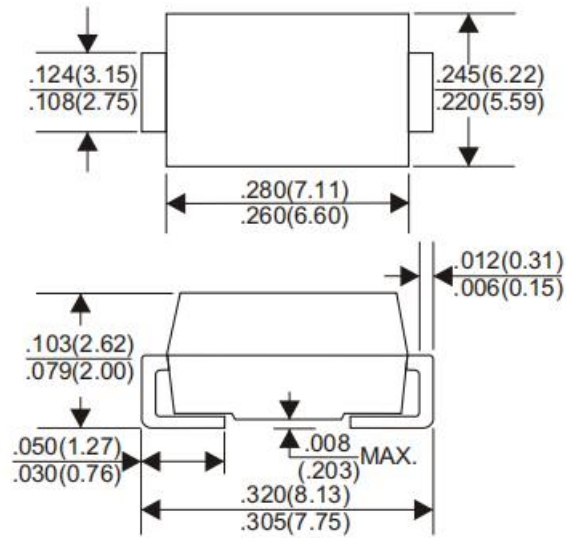

Dimensions in inches and (millimeters)