

**SOT-23-3L High Sensitivity Hall Switch 高灵敏度霍尔开关**

**■ Features 特点**

- 2.0V — 5.5V Battery Application 电池应用
- High Sensitivity High Reliability of Magnetic Switching 磁开关点的高灵敏度高稳定性
- Suit for Tamper Protection Switch 用于接近开关

**■ Internal Schematic Diagram 内部结构**

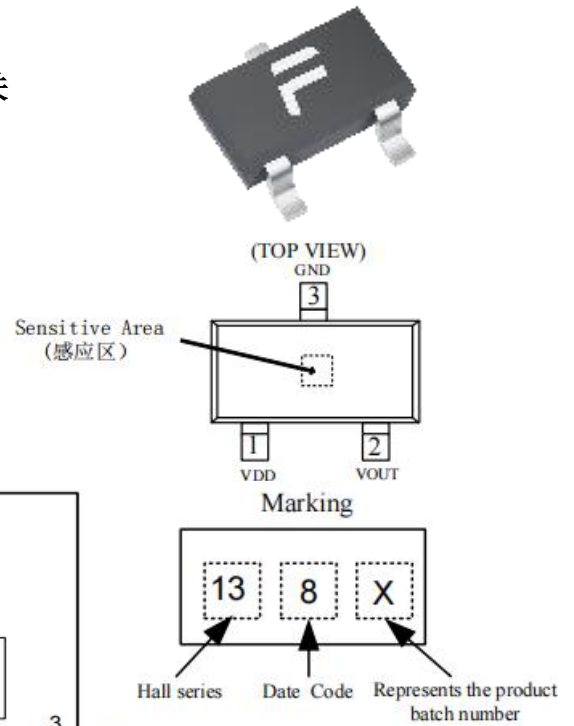
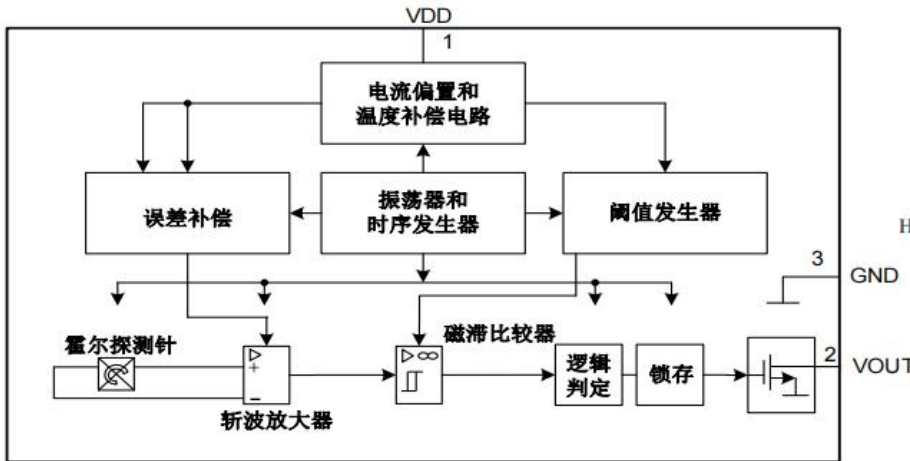

**■ Absolute Maximum Ratings 最大额定值**

Characteristic 特性参数	Symbol 符号	Rating 额定值	Unit 单位
Operating voltage 工作电压	$V_{DD}$	2~6	V
Operating Current 工作电流	$I_{DD}$	-1~4.5	mA
Output voltage 输出电压	$V_{OUT}$	-0.3~6	V
Output Current 输出电流	$I_{OUT}$	-1~2	mA
ESD 参数		4000	V
Junction Temperature 结温	$T_J$	150	°C
Storage Temperature 储存温度	$T_{stg}$	-45~+150	°C

■ Electrical Characteristics 电特性

(TA=25°C unless otherwise noted 如无特殊说明, 温度为 25°C)

Characteristic(Test Condition) 特性参数(测试条件)	Symbol 符号	Min 最小值	Type 典型值	Max 最大值	Unit 单位
Supply Voltage 供电电压(V <sub>DD</sub> =3V)	V <sub>DD</sub>	2.0	—	5.5	V
Average Supply Current 平均供电电流(V <sub>DD</sub> =3V)	I <sub>SAVG</sub>	1	3	10	μA
Operating Average Current 工作平均电流(V <sub>DD</sub> =3V)	I <sub>SOPAVG</sub>	0.5	2.0	3.5	mA
Operating Peak Current 工作峰值电流(V <sub>DD</sub> =3V)	I <sub>SOPT</sub>	—	—	4.5	mA
Standby Average Current 断态平均电流(V <sub>DD</sub> =3V)	I <sub>SSTB</sub>	1	1.9	8	μA
Output Saturation Voltage 输出饱和电压(I <sub>OUT</sub> =1mA)	V <sub>OSAT</sub>	—	0.13	0.4	V
Output Leakage Current 输出漏电流(V <sub>DD</sub> =3V)	I <sub>OLEAK</sub>	—	0.01	1	μA
Rise Time 输出上升沿时间(R <sub>L</sub> =2.7KΩ, C <sub>L</sub> =10pF)	t <sub>r</sub>	—	0.5	1	μS
Fall Time 输出下降沿时间(R <sub>L</sub> =2.7KΩ, C <sub>L</sub> =10pF)	t <sub>f</sub>	—	0.1	1	μS
Operating Time 工作时间	t <sub>op</sub>	25	100	160	μS
Standby Time 断态工作时间	t <sub>stb</sub>	60	140	240	mS
Duty Cycle 占空比	t <sub>op</sub> /t <sub>stb</sub>	—	0.071	—	%
Awake Time 芯片启动时间	t <sub>stu</sub>	—	12	20	μS

■ Magnetic Characteristics 磁特性

(TA=25°C unless otherwise noted 如无特殊说明, 温度为 25°C)

Characteristic 特性参数	Symbol 符号	Min 最小值	Type 典型值	Max 最大值	Unit 单位
South pole to part marking side(Operation Point) 南极对字标面(工作点)	B <sub>OPS</sub>	1	1.5	2	mT
North pole to part marking side(Operation Point) 北极对字标面(工作点)	B <sub>OPN</sub>	-2	-1.5	-1	mT
South pole to part marking side(Release Point) 南极对字标面(释放点)	B <sub>RPS</sub>	0.8	1.1	1.5	mT
North pole to part marking side(Release Point) 北极对字标面(释放点)	B <sub>RPN</sub>	-1.8	-1.1	-0.8	mT
Hysteresis 磁滞(B <sub>OPS</sub> -B <sub>RPS</sub> )	B <sub>HYS</sub>	0.1	0.4	0.7	mT

■ Application Circuit 应用电路

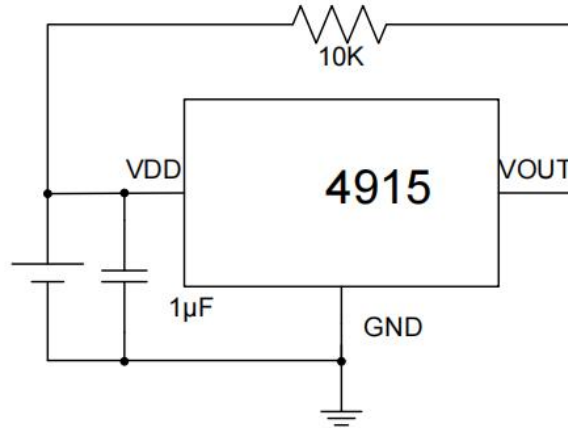

■ Typical Characteristic Curve 典型特性曲线

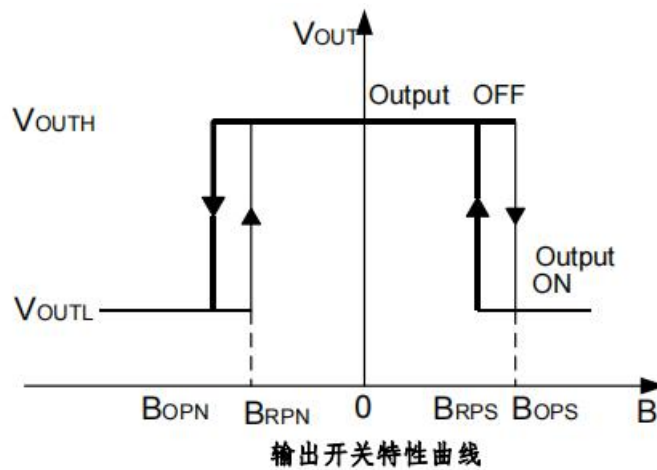
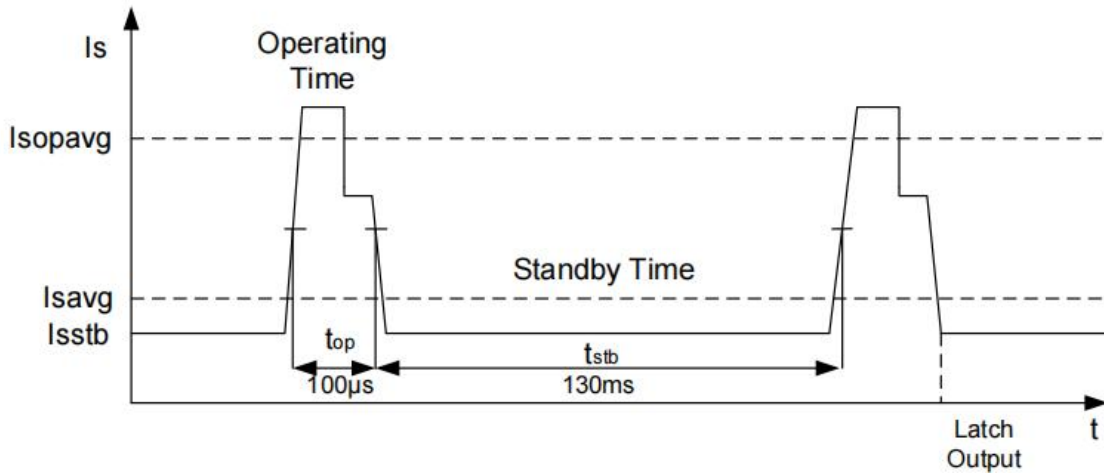

■ Dimension 外形封装尺寸

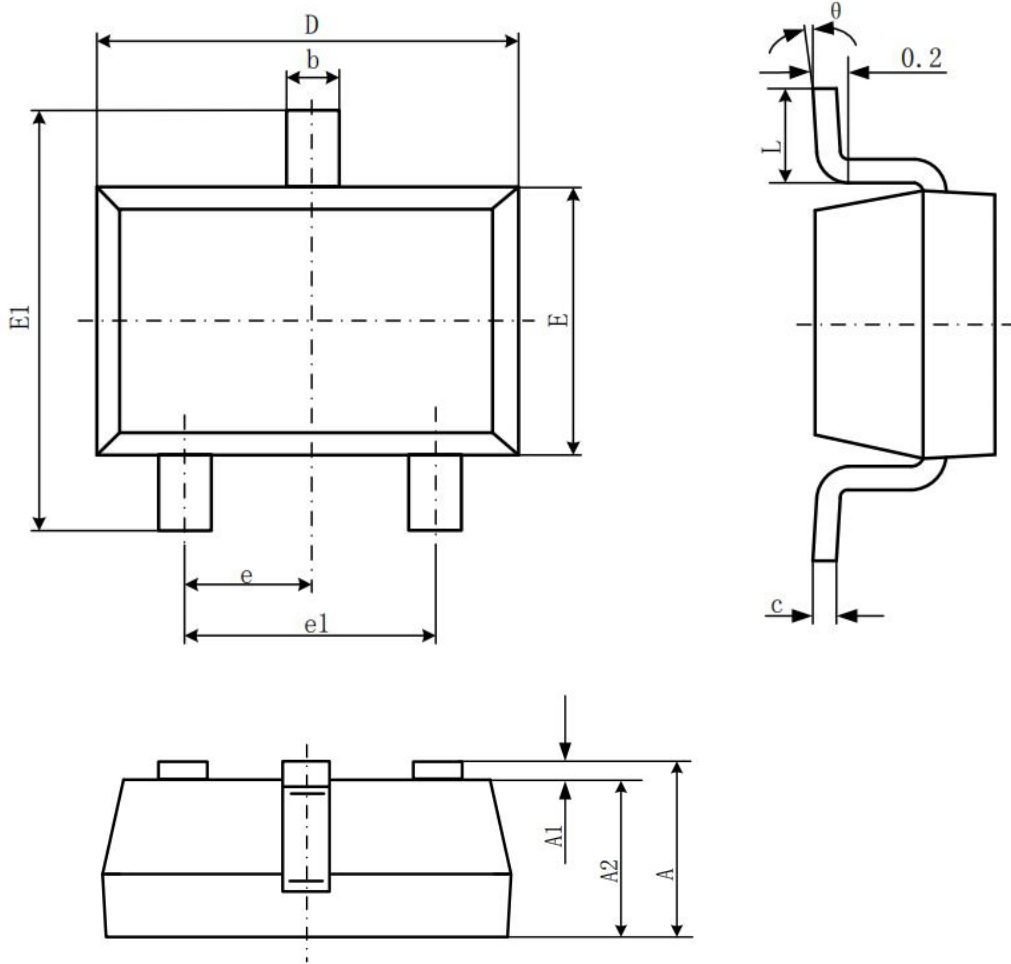

Symbol	Dimensions In Millimeters		Dimensions In Inches	
	Min	Max	Min	Max
A	1.050	1.250	0.041	0.049
A1	0.000	0.100	0.000	0.004
A2	1.050	1.150	0.041	0.045
b	0.300	0.500	0.012	0.020
c	0.100	0.200	0.004	0.008
D	2.820	3.020	0.111	0.119
E	1.500	1.700	0.059	0.067
E1	2.650	2.950	0.104	0.116
e	0.950(BSC)		0.037(BSC)	
e1	1.800	2.000	0.071	0.079
L	0.300	0.600	0.012	0.024
θ	0°	8°	0°	8°