

## SOT-23 ESD 静电保护二极管

### ■ Features 特点

Two Bidirectional Lines 两个双向  
ESD Protection 静电保护

### ■ Applications 应用

Portable electronics 便携式电子产品  
Control & monitoring systems 控制与监视系统  
Cellular handsets and accessories 蜂窝手机及配件  
Servers, notebooks, and desktop PCs bus protection  
服务器、笔记本及台式机总线保护

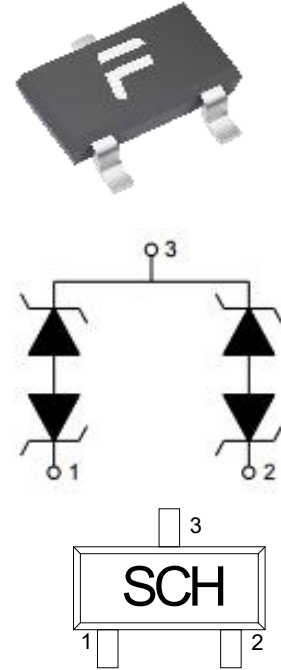

### ■ Internal Schematic Diagram 内部结构

### ■ Device Marking 产品打标

### ■ Absolute Maximum Ratings 最大额定值

Characteristic 特性参数	Symbol 符号	Rat 额定值	Unit 单位
ESD (IEC61000-4-2 contact discharge) @25°C接触放电	$V_{ESD}$	±30	KV
ESD (IEC61000-4-2 air discharge) @25°C空气放电	$V_{ESD}$	±30	KV
Peak Pulse Power @25°C峰值脉冲功率	$P_{PK}$	250	W
Peak Pulse Current @25°C峰值脉冲电流	$I_{PP}$	4	A
Lead Temperature 管脚温度	$T_L$	260	°C
Lead Solder Time 管脚焊接时间	$T_L$	10	S
Operating Temperature 工作温度	$T_{op}$	-40~85	°C
Junction Temperature 结温	$T_J$	-55~125	°C
Storage Temperature 储存温度	$T_{stg}$	-55~150	°C

■ **Electrical Characteristics 电特性**

( $T_A=25^\circ\text{C}$  unless otherwise noted 如无特殊说明, 温度为  $25^\circ\text{C}$ )

Characteristic Parameters 特性参数	Symbol 符号	Min 最小值	Typ 典型值	Max 最大值	Unit 单位	Condition 条件
Reverse Stand-off Voltage 反向工作电压	$V_{RWM}$			24	V	
Reverse Breakdown Voltage 反向击穿电压	$V_{BR}$	26.5	28		V	$I_T=1\text{mA}$
Reverse Leakage Current 反向漏电流	$I_R$			1	$\mu\text{A}$	$V_{RWM}=24\text{V}$
Clamping Voltage 钳位电压	$V_C$		38		V	$I_{PP}=1\text{A}, t_p=8/20\mu\text{s}$
Clamping Voltage 钳位电压	$V_C$		68		V	$I_{PP}=4\text{A}, t_p=8/20\mu\text{s}$
Diode Capacitance 二极管电容	$C_D$		15		pF	$V_R=0\text{V}, f=1\text{MHz}$

$V_{RWM}$	Reverse Working Voltage 反向工作电压
$V_{R(BR)}$	Reverse Breakdown Voltage 反向击穿电压@ $I_T=1\text{mA}$
$I_T$	Test Current 测试电流
$I_R$	Reverse Leakage Current 反向漏电流@ $V_{RWM}$
$V_C$	Clamping Voltage 钳位电压
$I_{PP}$	Reverse Peak Pulse Current 浪涌电流
$C_D$	Diode Capacitance 二极管电容 $V_{IO}=0\text{V}, V_{P-P}=30\text{mV}, f=1\text{MHz}$

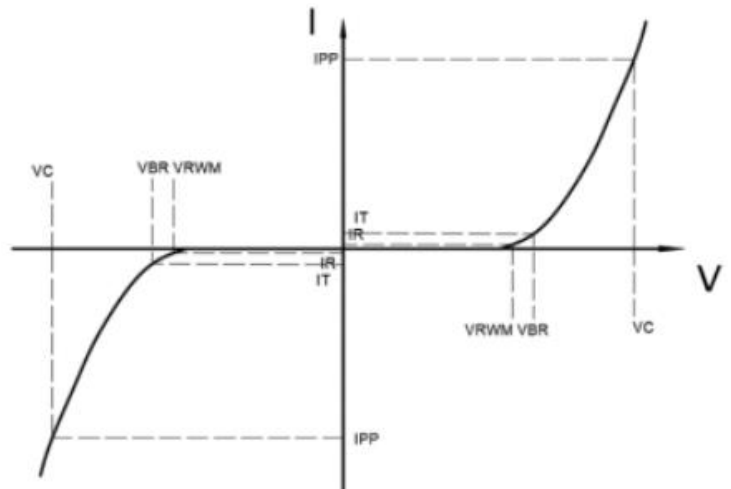

■ Typical Characteristic Curve 典型特性曲线

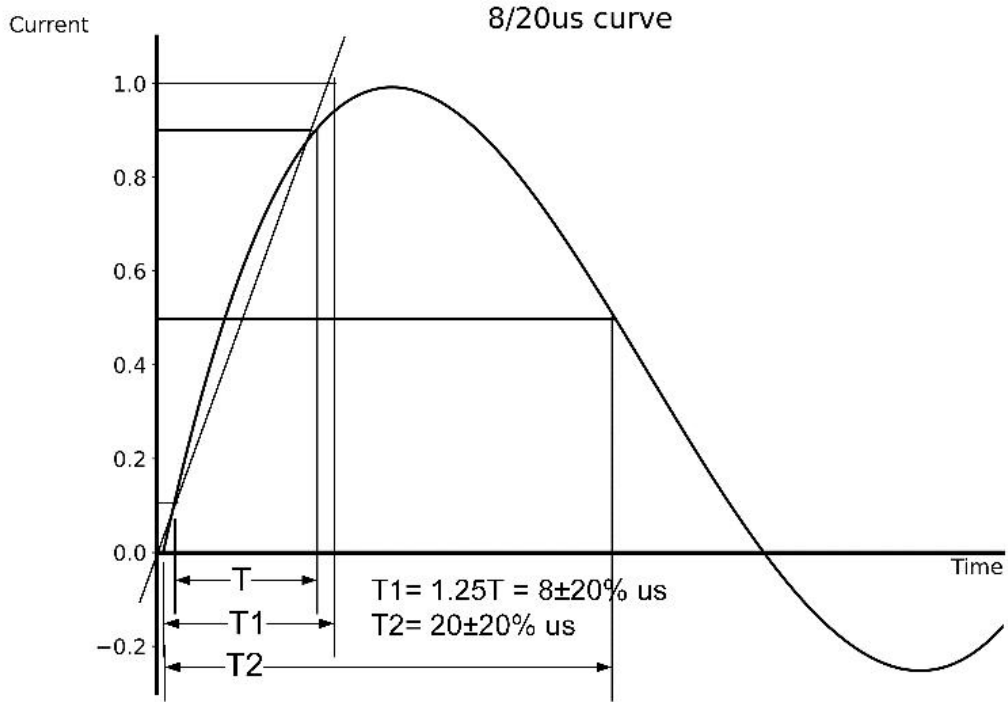

■ Typical Application 典型应用

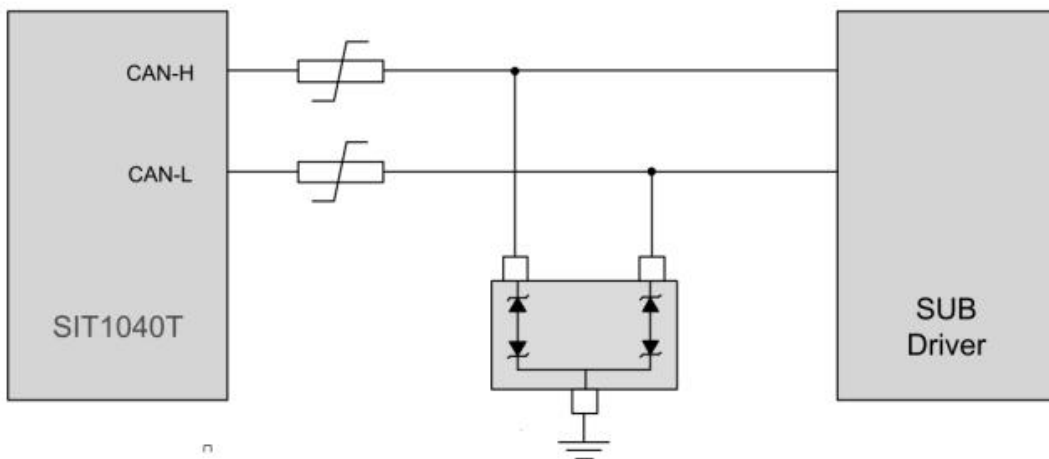

■ Dimension 外形封装尺寸

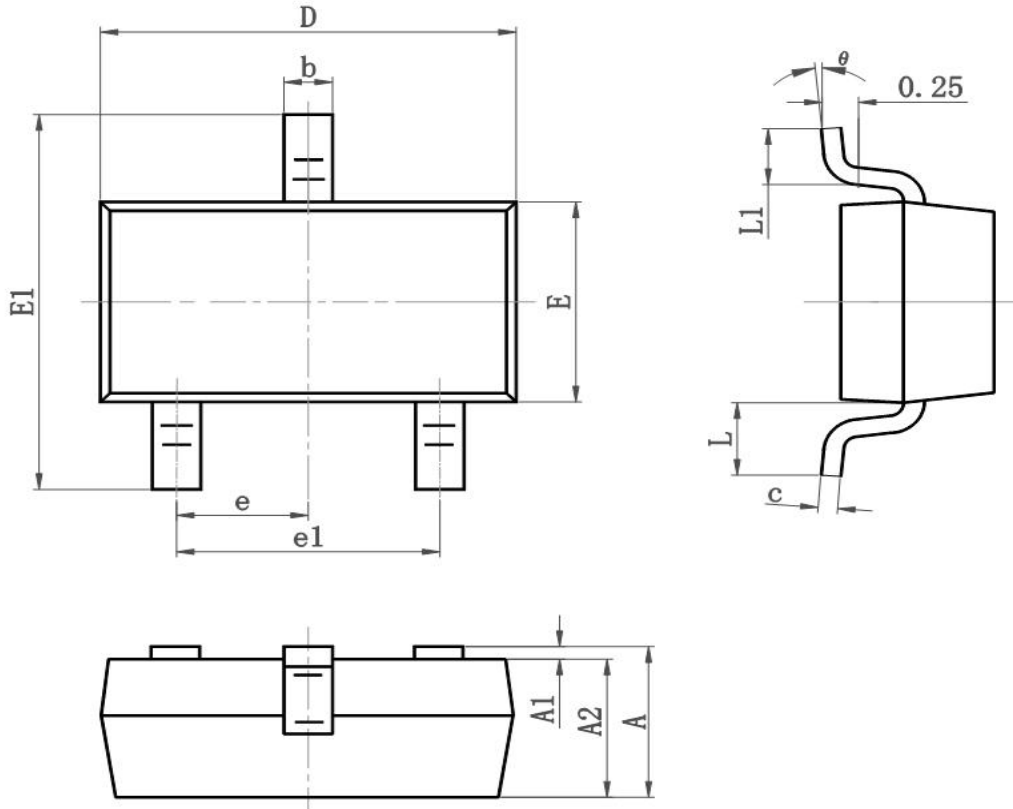

Symbol	Dimensions In Millimeters		Dimensions In Inches	
	Min	Max	Min	Max
A	0.900	1.150	0.035	0.045
A1	0.000	0.100	0.000	0.004
A2	0.900	1.050	0.035	0.041
b	0.300	0.500	0.012	0.020
c	0.080	0.150	0.003	0.006
D	2.800	3.000	0.110	0.118
E	1.200	1.400	0.050	0.055
EI	2.250	2.550	0.089	0.100
e	0.900	1.00	0.035	0.039
e1	1.800	2.000	0.071	0.079
L	0.500	0.600	0.020	0.024
L1	0.300	0.500	0.012	0.020
$\theta$	0°	8°	0°	8°