

SOD-323 ESD 静电保护二极管

■ Features 特点

Bidirectional 双向

Ultra-low Capacitance 超低电容

■ Applications 应用

I/O Interfaces 输入输出接口

Industrial and Serve Robots 工业和服务机器人

Laptops and Desktops 便携和台式电脑

TV and Monitors 电视和监视器

Wearables 可穿戴电子产品

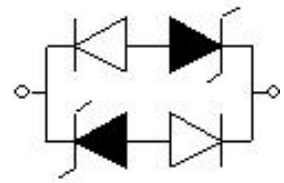

■ Device Marking 产品打标

$V_{RWM}(V)$	3	5
Marking	CC	AC/3B/LC

■ Absolute Maximum Ratings 最大额定值

Characteristic 特性参数	Symbol 符号	Rat 额定值	Unit 单位
ESD (IEC61000-4-2 contact discharge) @25°C接触放电	V_{ESD}	± 25	KV
ESD (IEC61000-4-2 air discharge) @25°C空气放电	V_{ESD}	± 25	KV
Peak Pulse Power @25°C峰值脉冲功率	P_{PK}	200	W
Lead Temperature 管脚温度	T_L	260	°C
Lead Solder Time 管脚焊接时间	T_L	10	S
Operating Temperature 工作温度	T_{op}	-40~85	°C
Junction Temperature 结温	T_J	-55~125	°C
Storage Temperature 储存温度	T_{stg}	-55~150	°C

■ **Electrical Characteristics 电特性**

($T_A=25^{\circ}\text{C}$ unless otherwise noted 如无特殊说明, 温度为 25°C)

Part No.型号	$V_{RWM}(V)$	$V_{R(BR)}(V)$	$V_C(V)@I_T=1A$	$I_{PP}(A)$	$V_C(V)@I_T=I_{PP}$	$I_R(\mu A)$	$C_J(pF)$
FSLC3D3V1BB	3.0	3.8	7.0	10.0	16.0	1.0	0.8
FSLC3D5V1BB	5.0	6.5	8.0	10.0	16.0	1.0	0.8

V_{RWM}	Reverse Working Voltage 反向工作电压
$V_{R(BR)}$	Reverse Breakdown Voltage 反向击穿电压@ $I_T=1mA$
I_T	Test Current 测试电流
I_R	Reverse Leakage Current 反向漏电流@ V_{RWM}
V_C	Clamping Voltage 钳位电压
I_{PP}	Reverse Peak Pulse Current 浪涌电流
C_J	Junction Capacitance 结电容 $V_{I0}=0V, V_{P-P}=30mV, f=1MHz$

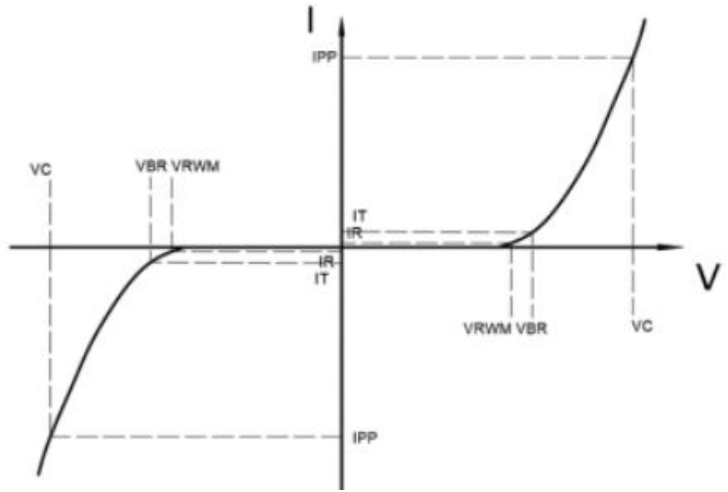

■ **Typical Characteristic Curve 典型特性曲线**

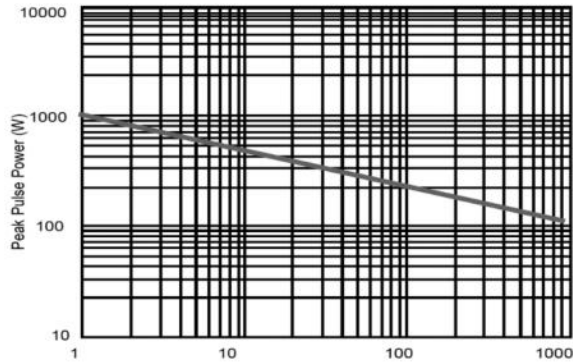

Non-repetitive peak pulse power vs. pulse time

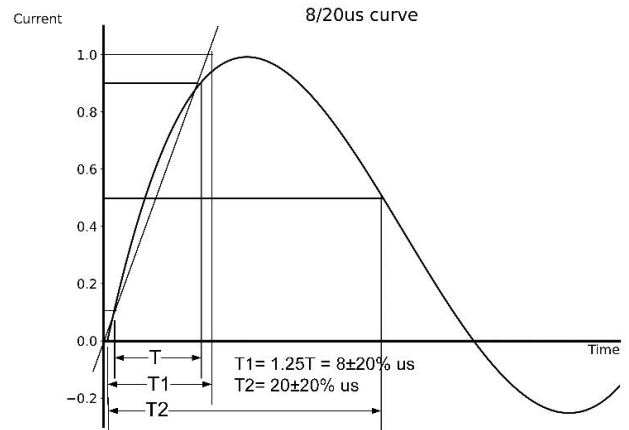

■ **Typical Application 典型应用**

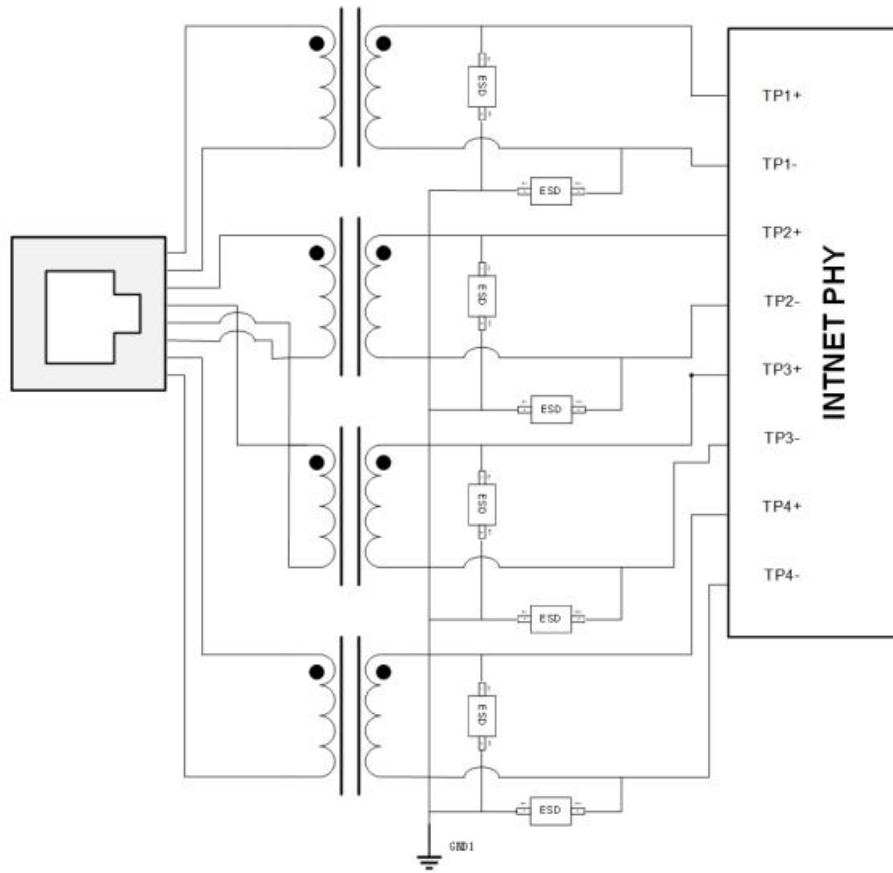

■ Dimension 外形封装尺寸

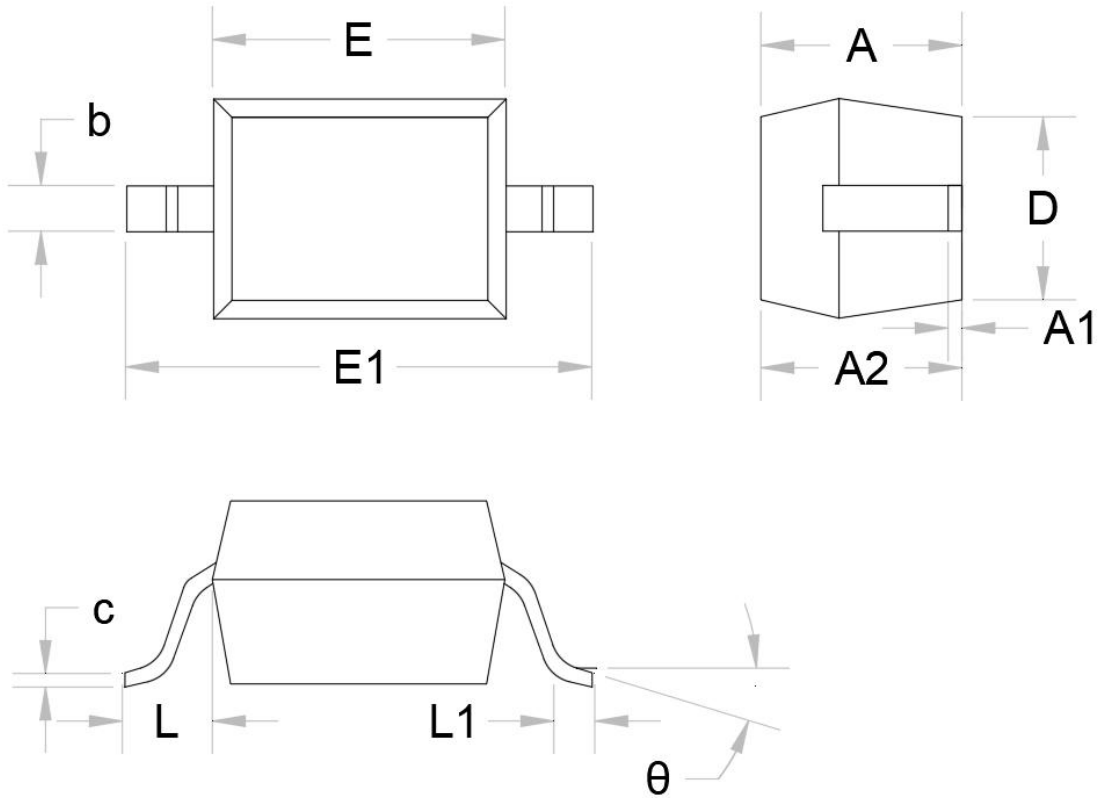

Symbol	Dimensions in Millimeters		Dimensions in Inches	
	Min.	Max.	Min.	Max.
A		1.000		0.039
A1	0.000	0.100	0.000	0.004
A2	0.800	0.900	0.031	0.035
b	0.250	0.350	0.010	0.014
C	0.080	0.150	0.003	0.006
D	1.200	1.400	0.047	0.055
E	1.600	1.800	0.063	0.071
E1	2.550	2.750	0.100	0.108
L	0.475REF		0.019REF	
L1	0.250	0.400	0.010	0.016
θ	0°	8°	0°	8°